

Model FT-TUB-B

Tubular Glass Gage Valve

Offset Pattern - 600 PSI Max

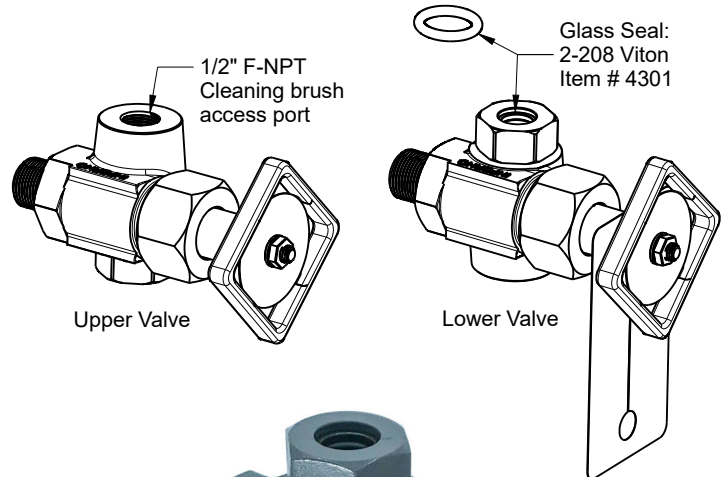
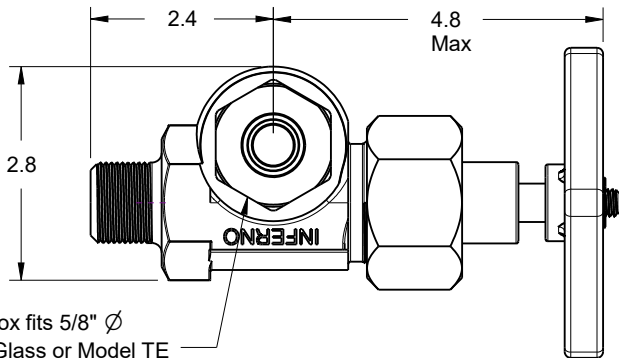
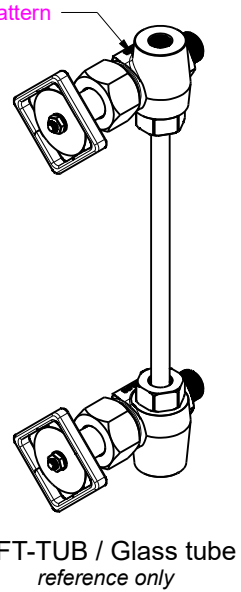
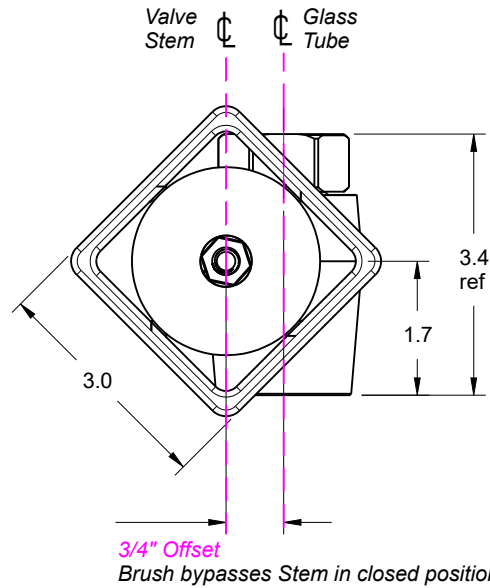
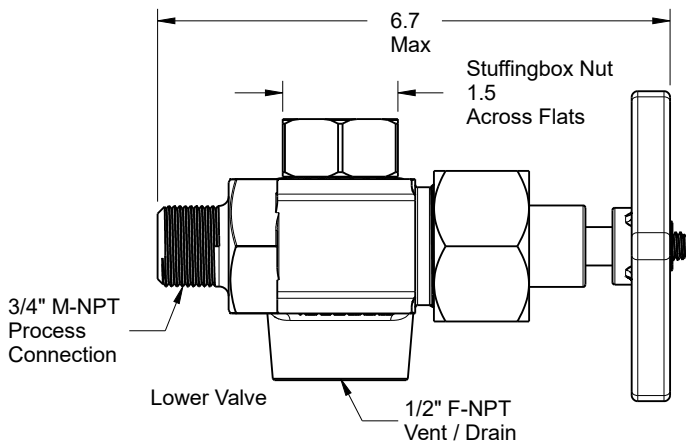

Design Detail

- * For use with 5/8" O.D. glass tube or Model "TE" sight glass
- * Forged Steel Construction, SS trim suitable for sour service
- * Patented Free Turn Design isolates the valve workings from salt water and H₂S - preventing internal corrosion that causes conventional valves to seize.
- * Offset Pattern allows cleaning brush access through valve body with valve stem closed
- * Features Safety Ball Checks in case of glass breakage
- * Easy glass seal replacement, Viton O'ring (400° F)
Options: TFE, Buna, Aflas, Kalrez
- * Pressure rating limited by glass length, service & temperature
- * Glass tube and Model TE length = C-C less 2" ± .125
- * All tubular gage valves sold in match sets: Upper & Lower
- * Design Change 2020: Stuffingbox Nut changed from 2" across flats to 1.5" across flats

FT "Free Turn"
Patent 6,991,216



Weight per Set: 10.5 Lbs

Reference Documents

- [FT "Free Turn" Advantages](#)
- [Model TE](#)
- [Hail Guard - Expanded Metal](#)



Inferno Manufacturing Corporation
115 Ricou St. Shreveport, LA USA 71107
T (318) 221-8454 F (318) 222-4106
inferno@infernomfg.com

Drawing No: **FT-TUB-B**

Drawing Date: 7/8/2020

Revision: 0

Rev Date:

© 2020 Inferno Mfg Corp

Sheet: 1/1