

Model FT25

Double Union, Offset Pattern Gage Valve Male x Female

For use with End Connected Gages (or Close Hook-up "CH")

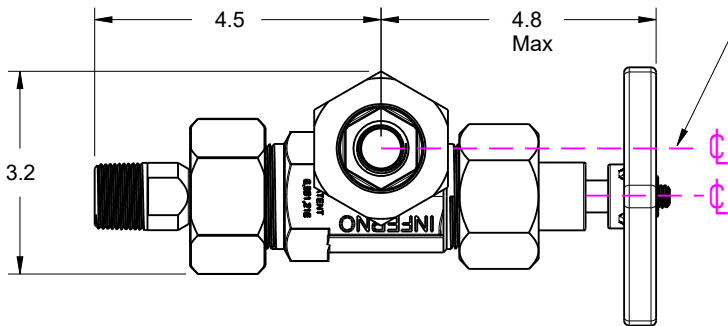
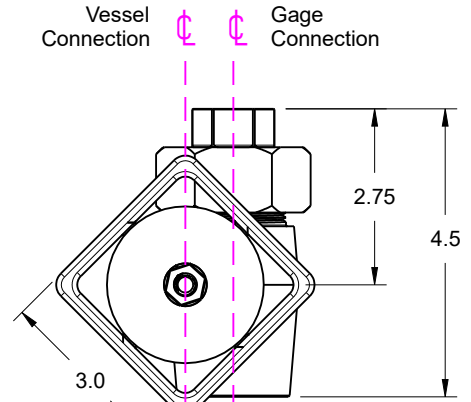
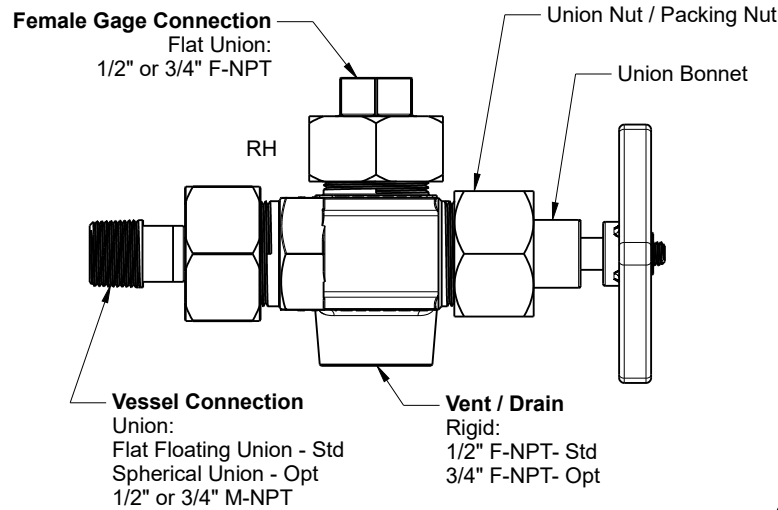

3/4" Offset
Cleaning brush bypasses stem in closed position

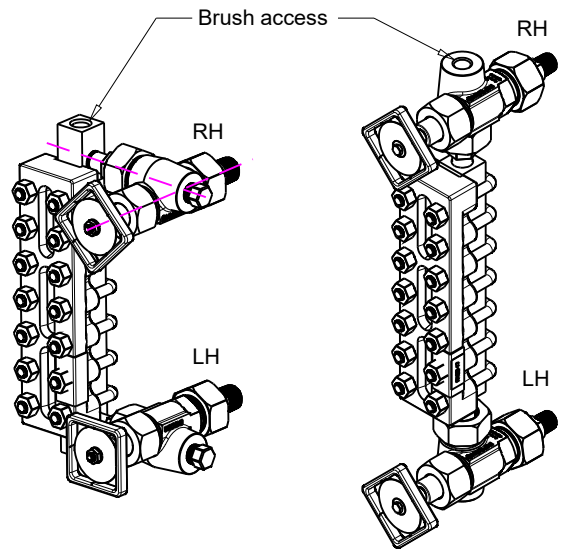

Close Hook-up "CH"
[Fig. 5-3-R shown](#)
"Offsets Inside"

End Connected
[Fig. 4-1 shown](#)

For other configurations see [GA.ASSY1](#)

RH shown

FT "Free Turn"
Patent 6,991,216

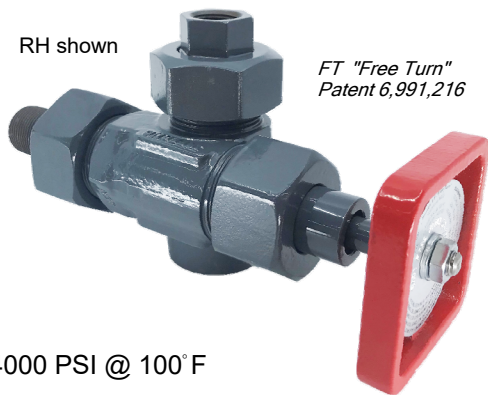

4000 PSI @ 100° F

Weight per Set: 15.25 Lbs

* Unique design - Stem packing located below the threads, isolates valve workings from salt water and H2S

* NACE MR-0175 conformance (wetted only)

* Valve set consists of RH and LH valve

Reference Documents

[FT "Free Turn" Advantages](#)

[GA.ASSY1](#)



Inferno Manufacturing Corporation

115 Ricou St. Shreveport, LA USA 71107

T (318) 221-8454 F (318) 222-4106

inferno@infernomfg.com

Drawing No: **Model FT25**

Drawing Date: 1/15/21

Revision: 0

Rev Date: N/A

© 2021 Inferno Mfg Corp

Sheet: 1/1