

- B. Locate the pressure gasket in the body recess. The gasket should be flat on the surface without lapping up on the sides of the recess.

Use pressure gasket thickness as follows:

- Column Gages: 1/32" thick
- Exception: 1/16" thick for TFE
- Weld Pad Gages: 1/16" thick

- C. Glass should be centrally located on the body and cover seats.

Glass should be taped at both ends, as shown in sketch, to help prevent the glass from making contact with the metal. Masking tape or some other soft tape is suitable for this purpose.

- D. Install bolts and nuts. The bolt and nut threads should be cleaned and lubricated before installing. Molybdenum disulfide lubricant is a good lubricant for this application. If threads show evidence of galling or corrosion the bolts and nuts should be replaced. Tighten all nuts finger-tight then tighten in sequence shown in Figure 3, in five (5) pound increments. Use torque wrench to obtain correct torque values. This procedure prevents excessive stresses from building up on the glass.

NOTE: The following torques are for our standard gages; lead lined, special shields or gaskets may require lower torque. If information has not been supplied with the gage, contact factory.

RECOMMENDED TORQUES

GAGE MODEL TORQUE (FT-LBS)

R100, RA, RDM	30 w Grafoil
T100, TA, TDM	30 w Grafoil
T200, TDH	30 w Grafoil
R200, RDH	42 w Grafoil
R13BC, R14BC etc	30 w Grafoil

A-TL-B	90
B-TE-D	110
TXT-11	35
19-14X (Bullseye)	Hand Tight
SFI (Sight Feed)	Hand Tight

WELD PAD GAGES

RWA	20
TWA	20

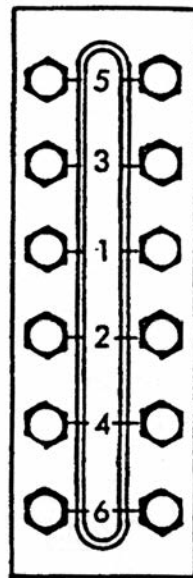

CAUTION: Bolts or nuts should not be tightened unless the gage is isolated from the vessel and the gage is vented to the atmosphere.

We recommend a hydrostatic test on the gage assembly at 1.3 to 1.5 times the operating pressure whenever possible, especially in high pressure applications.

FIGURE 3



INSTALLATION, OPERATIONS, AND MAINTENANCE of INFERNO LIQUID LEVEL FLAT GAGES

Inferno liquid level gages are designed and constructed to give satisfactory performance under a wide range of environmental and operating conditions.

Assuming the correct design and materials were specified at the time of purchase for the particular application, satisfactory service is dependent on reasonable care in the installation, operation, and maintenance of the gage assemblies.

INSTALLATION

Before installing the gage the following items should be considered.

- A. Avoid piping strains.
1. Connect and mount the gage to insure the gage does not support the piping or that misalignments do not exist in the piping to the gage.
 2. Make sure adequate provisions such as expansion loops or long piping runs between the gage and vessel exist when large differentials in temperature between the gage and vessel are present. Severe mechanical loads can be imposed on the gage or piping due to the thermal expansion.
 3. Support brackets should be provided for gages over 100 pounds in weight, especially so if the gages are subjected to vibration or shock environmental conditions, to prevent damage to the gage, valves, or piping.
- B. Provide shutoff valves between the gage and vessel. In case of an accident where the glass fails or a gasket blows a shutoff valve will reduce the loss of fluid.

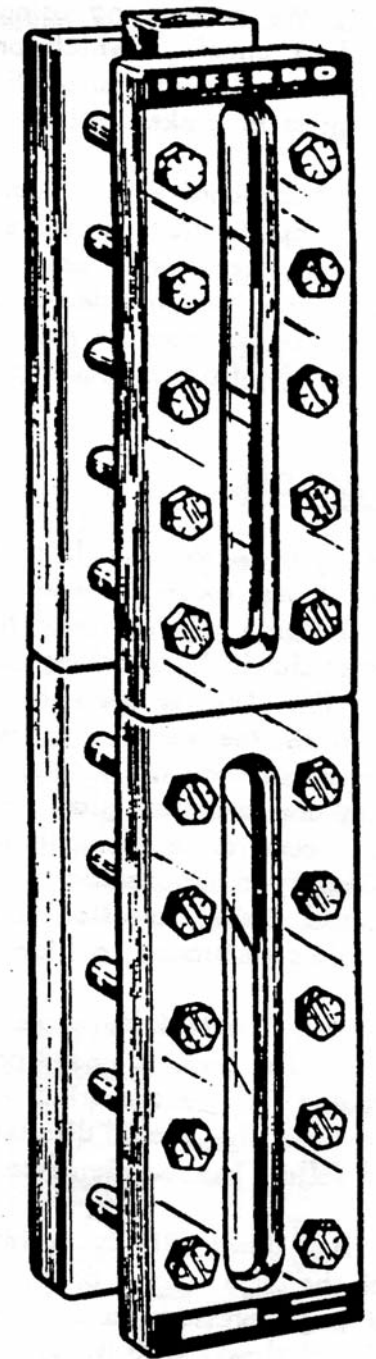

Also, a shutoff valve will allow removing or servicing the gage without draining the vessel. We recommend using gage valves with ball checks, which provide manual operation and quick automatic shutoff if a gage glass or gasket failure should occur.

- C. Additional safety features. For high pressure applications or severe environmental conditions additional protection for the operator can be provided by using a mirror mounted on the gage to permit the operator to view the fluid column from the side.

OPERATION

STARTING UP — When a large differential in temperature exists between the gage and vessel fluid, raise or lower the gage temperature slowly by cracking the gage valves all the way until the gage is either fully warmed up or cooled down. The glass used in Inferno gages are tempered glass which can stand large temperature shocks but the amount is limited by factors such as stresses imposed during installation which reduces the glass resistance to thermal shocks.

CAUTION: If a leak develops, do not torque nuts while gage is under pressure. Also if torquing to the specified torque does not eliminate the leak, disassemble the gage and follow the maintenance procedure.

SHUTTING DOWN — It is better to shut down with the gage valves open. This allows the gage pressure and temperature to be reduced slowly with the system. If the gage valves are closed off the gage should be vented to the atmosphere to prevent pressure build-up in the gage, especially when the gage is cold.



MAINTENANCE

Proper tools and equipment are important in making the maintenance job easier and for the best results.

Below is a list of equipment that can be readily purchased and kept in a kit to make the job easier.

1. Socket head wrench for bolt heads.
2. Socket head torque wrench for torquing nuts.
3. Open end or crescent wrench for torquing reflex gage set screws.
4. Assortment of sockets depending on gage bolt sizes for use with socket wrenches.
5. Scraper for preparing gasket surfaces on gage body and clamps. Use soft materials such as brass to prevent making burrs. Bolt lubricant – molybdenum disulfide lubricant.
6. Soft tape. Such as 1/2" masking tape for ends of glass to prevent glass to metal contact when installed in the gage.
(See figure 1)

Alternative: Use #32 Rubber Band, P/N 10952

DISASSEMBLY

Loosen bolts in opposite sequence from that shown in sketch for tightening bolts (opposite ends toward center). It is preferable to loosen the bolts a small amount at a time in sequence instead of loosening a bolt completely when the other bolts are fully torqued.

Whenever possible the gage should be removed from service to a bench so the gage can be worked on in a horizontal position.

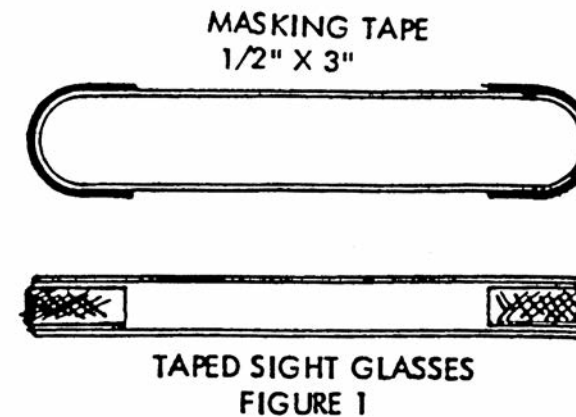

REASSEMBLY

See sketches in Figure 2 of the different type gages to see basic arrangements, for the reflex and transparent gages.

Used pressure gaskets or cushion gaskets should not be used even when they appear to be in good condition. Used glasses may appear to be in good shape but as a general rule are not as reliable as new glasses. The replacement glass should be free of scratches or chips that may cause local stress concentration.

The glasses used in Inferno gages have a low coefficient of expansion, resistant to thermal shock and resistance to bending loads. Nevertheless, care should be taken to prevent loads on the glass which will cause bending or stress in the glass.

The following is a list of items that should be observed to ensure satisfactory service.

- A. The gasket surface on the gage body and covers should be flat to provide a flat surface for mounting the sight glass.

A soft scraper should be used to remove the old gasket. All burrs and gasket material or other residue should be removed from the surfaces. Gouged or scarred seats should be refinished by milling. If the seats show evidence of corrosion, pitting or cracking, a careful investigation should be made to determine whether the part should be used and whether the material selection is suitable for the application.

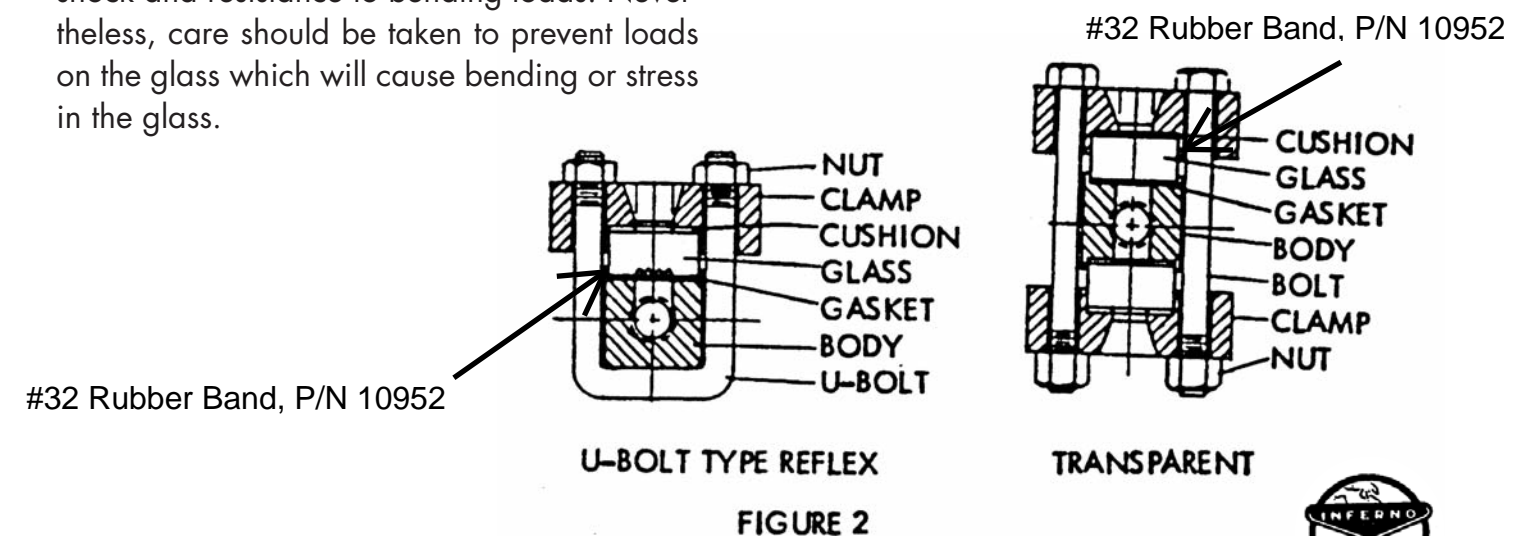

ASSEMBLY INSTRUCTIONS, Level Gage w Wrap-Around Covers

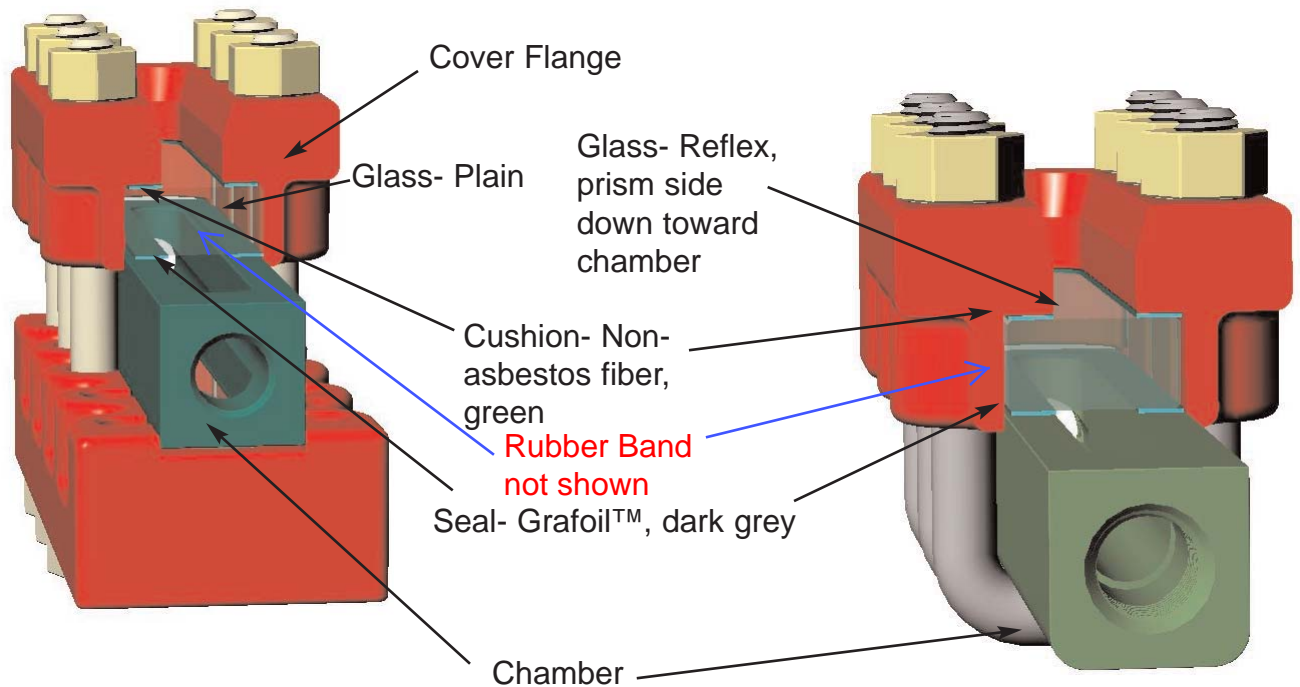

BOLT TORQUE:

R100, T100 & T200 Series:	30 Ft-Lbs w lubrication
RDM, TDM, TDH Series:	30 Ft-Lbs w lubrication
R200 & RDH Series:	42 Ft-Lbs w lubrication

The gasket surfaces on the gage chamber and cover should be flat to provide a flat surface for mounting the glass.

Stretch rubber band around periphery of glass to create a soft bumper so that glass does not contact the sides of the recess in the cover flange. If rubber band is not available then use 1/2" wide x 3" long strips of masking tape to build up a bumper at each end of glass. Several layers may be required. Glass should be centered in the recess of the cover flange.

Lubricate the bolt threads and the bearing surface of the nuts. This will insure even and thorough tightening of the bolts. Use oil, cup grease or "Anti-Seize" lubricant.

Bolting will not become tight enough if torqued in dry condition, may lead to seal **blow-out.** Lubrication increases tightness of joint.

Use a torque wrench; do not try to tighten without torque wrench.

Grafoil™ (flexible graphite) is fragile, handle with care

1. Locate the sealing gasket (pressure gasket) on top of the chamber and center it over the slot in the chamber.
2. Protect sides of glass from contact with cover flange by using rubber band.
3. Place glass on top of seal gasket. Place green cushion gasket on top of glass.
4. Lower the cover flange over the stack.
5. Tighten bolting in small increments, starting with center bolts and working out towards each end. Multiple visits to each nut is required.